



INTRINSPAK



Installation Instructions Series 9000 Intrinspak® Intrinsic Safety Barriers

General Description

The Series 9000 Intrinspak® Intrinsic Safety Barriers are designed to provide intrinsically safe connections to process sensors located in potentially hazardous locations. These sensors may be either approved Intrinsically Safe Apparatus such as solenoid valves and transmitters, or Simple Apparatus such as RTDs, thermocouples, and LED indicators. Reference should be made to the process sensor manufacturer's documentation and the R. Stahl Certification Drawing indicated below.

Electrical Characteristics

Rated Voltage	Refer to RST49 Product Catalog
Rated Current	Refer to RST49 Product Catalog
Internal Resistance	Refer to RST49 Product Catalog
Replaceable Fuse Rating	160mA (one per channel on Type 9002)
Pole Reversal Protection	Protected by replaceable fuse
Current Limitation	
Type 9001	Resistive
Type 9002	Resistive
Type 9004	Electronic

Transmission Characteristics

Leakage Current	≤ 1µA unless stated otherwise
Temperature Effect	≤ 0.25%/per 10K
Short Circuit Proof	Yes, unless stated otherwise
Frequency	
Type 9001	≤ 100kHz @ $I_{sc} > 50mA$ ≤ 50kHz @ $I_{sc} ≤ 50mA$
Type 9002	≤ 100kHz @ $I_{sc} > 50mA$ ≤ 50kHz @ $I_{sc} ≤ 50mA$
Type 9004	≤ 10kHz

Vibration Resistance

Vibration Frequency	55Hz
Vibration Amplitude	± 0.006in. (± 1.5mm)
Shock Resistance	20g

Ambient Conditions

Operating Temp. Range	-4° to +140°F (-20° to +60°C)
Storage Temp. Range	-40° to +167°F (-40° to +75°C)
Relative Humidity Range	to 95%, no condensation

Grounding Method

Electrical connection is made between barrier and mounting platform (NS35/15 DIN rail). This mounting platform must be connected to designated ground electrode. Two additional terminals are provided for grounding each barrier and for termination of shielded cable.

Mounting Method	NS35/15 DIN Rail
	A1-0006 Universal Busbar
	A1-0004 Busbar
	Surface Mount

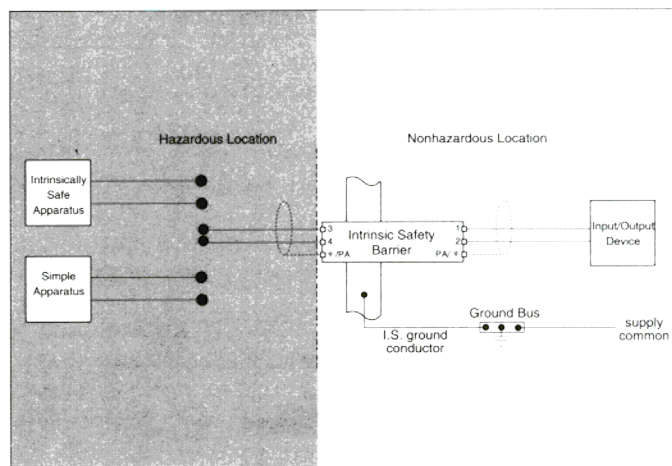


Figure 1. Application of Series 9000 Intrinspak® Intrinsic Safety Barriers

Mounting Location

Nonhazardous or Class I, Div. 2 location.

Mechanical Specifications

Housing Material	Polyamide
Degree of Protection	IP40 to IEC 529
Flame Resistance	Self extinguishing to IEC924, UL94, ASTM D635-77
Weight	0.22 lbs. (100 grams)
Screw Terminal Size	Four #12 AWG (1.5mm ²) captured, self-opening Two #10 AWG (4.0 mm ²) for ground and shield
Screw Terminal Material	#12 AWG Terminals Copper-Zinc alloy #10 AWG Terminals Copper-Tin alloy

Certification Drawing

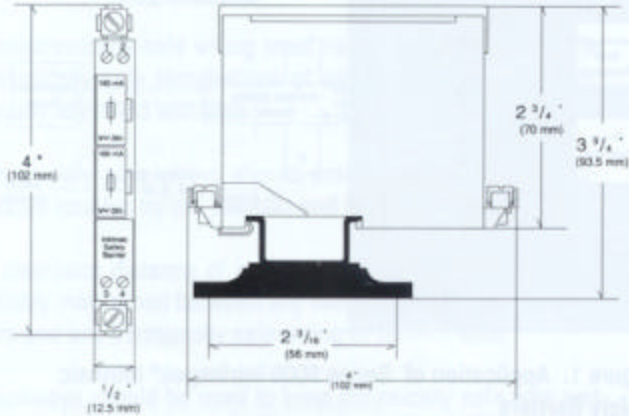
Type 9001	90 016 01 31 0 (specify agency)
Type 9002	90 026 01 31 0 (specify agency)
Type 9004	90 046 01 31 0 (specify agency)

Test Certificates

FM	
Type 9001	FM 3610 (J.I. 3T9A1.AX)
Type 9002	FM 3610 (J.I. 3T9A2.AX)
Type 9004	FM 3610 (J.I. 3T9A3.AX)
PTB	
Type 9001	EN 50014/ 50 020(Ex-91.C.2046X)
Type 9002	EN 50 014/50 020(Ex-91.C.2045X)
Type 9004	EN 50 014/50 020(Ex-92.C.2013X)
UL	
Type 9001, 9002, 9004	UL913 (E 81680)
CSA	
Type 9001, 9002, 9004	CSA 22.2 No. 157 (LR43394)
SA	
Type 9001	AS 2380 (Ex-1464X)
Type 9002	AS 2380 (Ex-1473X)
Type 9004	AS 2380 (Ex-1480X)
MSHA	
Type 9001, 9002, 9004	(Consult R. Stahl)
JIS	
Type 9001, 9002, 9004	(applied for)

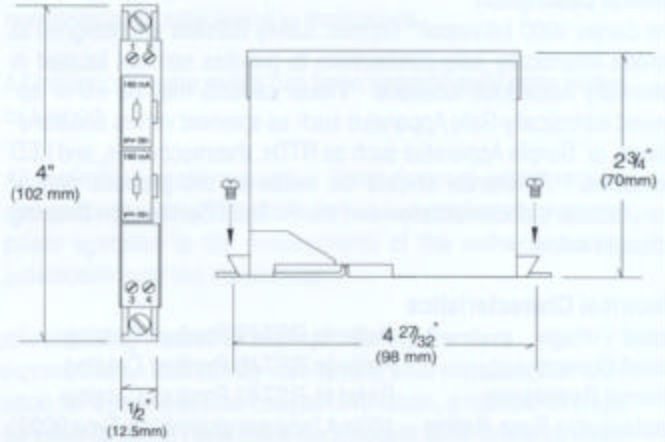


Figure 2. Mounting and Dimensional Information



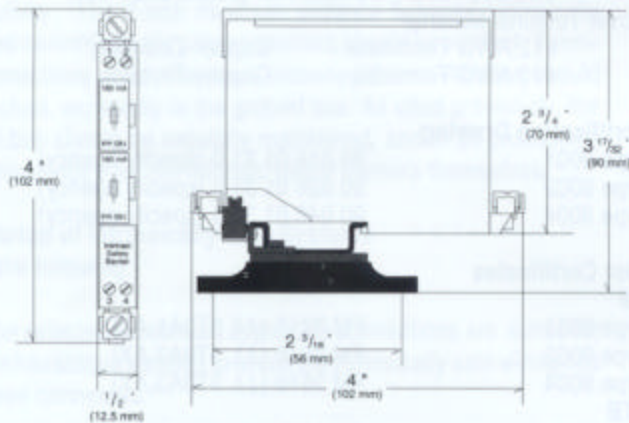
NS35/15 DIN Rail Assembly

The Series 9000 is designed to mount directly to an NS35/15 DIN Rail Assembly available from R. Stahl. This assembly consists of a user specified length of DIN rail, SSO-002 insulated standoffs- at 12" intervals, and two USLKG-4Ex ground terminals. Each barrier requires 1/2" of rail space. Once mounted, this rail becomes the ground bus for all barriers mounted on that rail. A 12 AWG or larger ground wire should be taken from the USLKG-4Ex to the designated ground point.



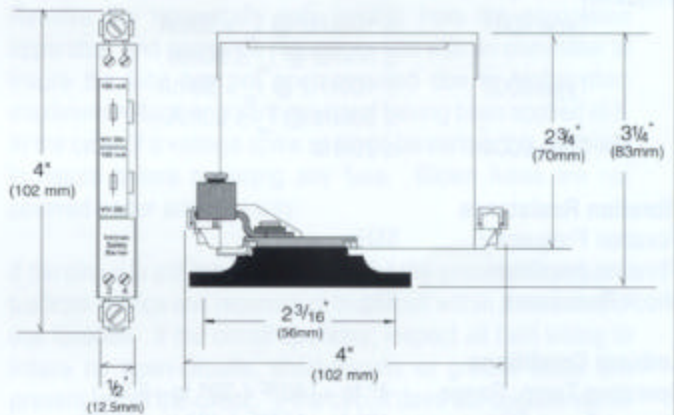
Surface Mount

The Series 9000 may be mounted directly to a PCB or other flat surface with the use of the factory installed MBA-001 adapter.



A1-0004 Busbar Assembly

For installations that use the A1-0004 Busbar Assembly, an adapter is required for mounting the Series 9000. It consists of a user specified length of A1-0002 busbar, SSO-002 insulated standoffs- at 12" intervals, and two SLU-35 ground terminals. This busbar becomes the intrinsic safety ground bus and should be grounded at the designated grounding point.



A1-0006 Universal Busbar

For installations that use the A1-0006 Busbar Assembly, no adapter is required for mounting the Series 9000. This busbar is specially machined to allow direct mounting of the Series 9000 as well as all previous series of R. Stahl barriers. It consists of a user specified length of A1-0005 busbar, SSO-002 insulated standoffs- at 12" intervals, and two SLU-35 ground terminals. This busbar becomes the intrinsic safety ground bus and should be grounded at the designated grounding point.

Fuse Assembly Replacement

All Series 9000 Intrinspak® Intrinsic Safety Barriers are equipped with standard replaceable 160mA fuses. They are located on the top face of the barrier for easy access. With a small instrument screwdriver, simply pry off the protective cover where indicated and remove the assembly. This may be done even while the circuit is energized. To install the replacement assembly, simply snap it back into place.

Spare Parts and Accessories

NS35/15	DIN Rail <i>specify length in inches</i>
011239	Fuse assembly(160mA)
SFH-001	Spare Fuse Holder <i>includes 5 fuses</i>
029959	Loop I.D. Tag Holder
022297	Loop I.D. Tag Paper
022231	Adapter
871646	Adapter, Metal
881109	Adapter, Plastic
821470	Ground Terminal, 12 AWG
821488	Ground Terminal, 10 AWG
SSO-002	Standoff, Insulator
ISL-001	Label, 5" DIA, "I.S. System"
ISL-002	Label, 3.5" DIA, "I.S. System"
ISL-003	Label, Cable Tray, "I.S. Wiring"
ISL-004	Label, Conduit, "I.S. Wiring"
ISL-005	Label, Ground, "I.S. Wiring"

Wiring Instructions

All Series 9000 Intrinspak® Intrinsic Safety Barriers have six terminals. Terminals (3) and (4) are the intrinsically safe connections. Devices in the hazardous location are connected to these terminals. Terminals (1) and (2) are the nonintrinsically safe connections for devices within the nonhazardous location. The maximum source voltage which could be applied to these terminals under a fault condition must not exceed 250V rms.

Along with the four terminals mentioned above, two additional screw terminals are provided, one on each side of the barrier. They are directly attached to the barrier mounting/grounding system and can be used to establish a redundant ground system or for terminating shields. On single channel barriers (Type 9001) they are also internally connected to terminals 2 and 4.

Since a common housing is shared between single, dual, and application dedicated barriers, refer to the schematic printed on the side of each barrier to determine the designation of the floating and grounded terminals.

Special attention must be given to the grounding system. Without a proper earth ground system, intrinsic safety barriers will not provide voltage protection. They must therefore be grounded to a designated grounding electrode which references the original power source and instrumentation within the nonhazardous location. The ground conductor shall be no smaller than a #12 AWG size wire and the ground path resistance from the farthest barrier to this ground point shall not exceed 1Ω.

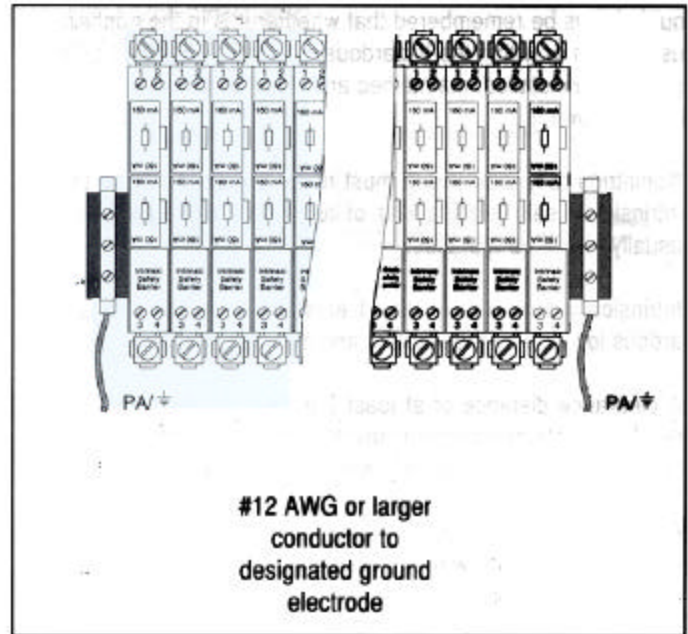


Figure 3. Typical grounding arrangement of Series 9000 Intrinspak® Intrinsic Safety Barriers

Installation of Intrinsically Safe Systems

It is important that the installer of an intrinsically safe system reference the requirements of the "authority having jurisdiction" at the installation site. In the United States reference should be made to Article 504 of the National Electrical Code, the ISA RP 12.6 and the manufacturer's certification drawing.

Where possible, associated apparatus should be mounted and grounded in a safe area as near to the hazardous area as possible. This will minimize the length of intrinsically safe conductors within the nonhazardous location, thereby lessening the possibility of inadvertent connection of nonintrinsically safe energy to the protected circuit. R. Stahl recommends that associated apparatus be mounted and installed within dust and moisture free enclosures. While this requirement is not part of any referenced standard it should be remembered that dust and moisture are conductive and can lessen the required distance ($\geq 2"$ or 50 mm) between intrinsically safe and nonintrinsically safe conductors. In addition, the panel layout of these enclosures should be constructed so that the separation of intrinsically safe and nonintrinsically safe conductors is maximized.

In cases where it is necessary or desired to mount associated apparatus within a Division 1 hazardous location they must be placed within an enclosure suited for that environment, i.e., explosionproof or purged. In such instances, the requirements relative to those systems and installations must be adhered to. For installation within a Division 2 hazardous location reference should be made to the approval report of the respective testing agency.

It should always be remembered that whether it is in the nonhazardous location or within the hazardous location, intrinsically safe wiring must be installed, maintained and repaired with consideration to the following:

Nonintrinsically safe wiring must never be connected to the intrinsically safe terminations of any associated apparatus, usually identified with blue.

Intrinsically safe wiring should enter or leave the nonhazardous location by the shortest and most direct route.

A clearance distance of at least 2 inches (50 mm) must be reliably maintained between any nonintrinsically safe conductors and any intrinsically safe wiring or terminations.

Raceways should be used to keep intrinsically safe wire and nonintrinsically safe wire separated. Wire lacing or ties are acceptable as well.

Intrinsically safe conductors must be identified, either by color coding with light blue jacketed cable, or by tagging at regular intervals, which the NEC identifies as every 25 feet.

Maintenance

The condition of associated apparatus should be checked periodically. During these inspections any accumulated dust, moisture or corrosion should be removed to ensure good conductor to terminal conductivity. The 2 inch minimum distance between intrinsically safe and nonintrinsically safe conductors should be verified. Terminal connections which may have loosened due to vibration should be checked, especially in the ground bus. As cited previously, the ground bus should be regularly maintained, and in all probability, more frequently than the intrinsic safety barriers themselves.

Pre-startup of Intrinsically Safe Systems

Verify the following:

The selected associated apparatus connections are suited for the hazardous location to which the intrinsically safe wiring has been connected.

The ground connection is less than 1 Ω in installations using intrinsic safety barriers.

No electrical equipment with a primary source voltage in excess of 250 V is connected within the intrinsically safe control system. This includes energy which is being switched through relays within the intrinsically safe circuit (s).

The voltage source to each associated apparatus does not exceed its maximum voltage rating.

The 2 inch minimum distance between intrinsically safe and nonintrinsically safe wiring is maintained.

All intrinsically safe wiring has been appropriately color coded or tagged.

All intrinsically safe apparatus (field devices) which require approvals and/or certifications have been evaluated by appropriate agencies to the requirements of the authority having jurisdiction over the installation.

Troubleshooting Resistive Intrinsic Safety Barriers

In the event that an intrinsically safe circuit, after installation or after operation for a period of time ceases to function, a number of steps may be taken to identify and solve the problem. The following steps will assist the user in identifying problems should they appear:

Make sure that the circuit is powered.

Recalculate the circuit load and voltage drops to identify any overloading problems.

Make sure that any electrical equipment which may have been added to the circuit has not created a loading problem.

Remove the intrinsically safe lead(s) from the associated apparatus and perform a resistance test with an ohmmeter to insure the fuse has not open-circuited due to higher than maximum voltage or polarity reversal having been applied to it. In the case of a voltage spike or surge be certain it is transient in nature before replacing any fuse. Blown fuses are not covered under any warranty.

If the circuit is still inoperative, remove the associated apparatus from service and reconstruct the circuit within a nonhazardous location. If the circuit operates, inspect all field wiring to insure no open-circuits, short-circuits or ground faults are present within the circuit. If the circuit does not operate within the reconstructed circuit remove the intrinsic safety barrier(s) from ground. This will prevent the zener diodes from conducting. Should the circuit then begin to operate, contact R. Stahl for further assistance.

If the intrinsic safety barrier is not a resistive type, and a problem is suspected, please consult R. Stahl for testing parameters.

